



# **BYD Battery-Box Pro User Manual**

**Battery-Box Pro 2.5~10.0**

---

# Contents

<b>1 General Information</b> .....	<b>2</b>
1.1 Validity.....	2
1.2 Application.....	2
1.3 Intended use .....	2
1.4 Battery-Box and B-Plus L definition.....	2
1.5 Identifying the product .....	3
<b>2 Safety</b> .....	<b>3</b>
<b>3 Technical Data</b> .....	<b>5</b>
<b>4 Technical Terms</b> .....	<b>6</b>
<b>5 Product Overview</b> .....	<b>6</b>
5.1 Brief introduction of Battery-Box system.....	6
5.2 Configuration table .....	7
5.3 Introduction of BMU.....	7
5.4 Introduction of B-Plus L 2.5 .....	8
5.5 Operating environment.....	9
<b>6 Cleaning and Maintenance</b> .....	<b>9</b>
6.1 Cleaning .....	9
6.2 Maintenance.....	9
6.2.1 Recharge requirement for batteries in normal storage .....	9
6.2.2 Recharge requirement for over discharged batteries.....	10
<b>7 Compatible Inverter List</b> .....	<b>10</b>
<b>8 Common Issues and Solutions</b> .....	<b>10</b>
8.1 Alarm indicated by the BMU and solution .....	10
8.2 Alarm displayed on B-Plus L 2.5 and solution.....	10
8.3 Common issues displayed on inverter and solution.....	12
8.4 Emergency .....	12
<b>9 Warranty</b> .....	<b>13</b>
<b>Contact Information</b> .....	

# 1 General Information

## 1.1 Validity

This user manual applies to the Battery-Box Pro 2.5, Battery-Box Pro 5.0, Battery-Box Pro 7.5, and Battery-Box Pro 10.0.

## 1.2 Application

This user manual introduces the Battery-Box product information, using guidance, safety, common issues and actions.

The Battery-Box Pro 2.5-10.0 is an energy storage unit that can be used in ON-grid system or Off-grid system for residential application.

The product is suitable for indoor use only.

## 1.3 Intended use

The Battery-Box is not suitable for supplying life-sustaining medical devices. A power outage must not lead to personal injury.

Use this product only in accordance with the information provided in the enclosed documentation and with the locally applicable standards and directives. Any other application may cause personal injury or property damage.

The illustrations in this manual meant only to help explain system configuration concepts, includes using guidance, safety caution and normal failure and actions.

Alterations to the product, e.g. changes or modifications, are only permitted with the express written permission of BYD. Unauthorized alterations will void warranty claims. BYD shall not be held liable for any damage caused by such changes. Any use of the product other than that described in the Intended use section does not qualify as appropriate. The enclosed documentation is an integral part of this product. Keep the documentation in a convenient place for future reference and observe all instructions contained therein. The type label must be attached to the product.

Battery-Box Pro series products must work with compatible inverters which are listed in the Battery-Box Pro 2.5~10.0 Compatible Inverter List.

Please contact BYD or local after service providers within one week once the user decides to cease using their Battery-Box products

The Battery-Box products can be installed at altitude of up to 2000m above the Mean Sea Level.

## 1.4 Battery-Box and B-Plus L definition

BYD Battery-Box products Battery-Box Pro 2.5~Battery-Box Pro 10.0 are defined as below:

Battery-Box: Battery Box

B-Plus L 2.5: Battery unit with 2.56kWh nominal capacity, which can be installed inside the cabinet as an energy storage module.

Battery-Box Pro 2.5: Battery nominal capacity is 2.56 kWh (Includes 1pc B-Plus L 2.5)

Battery-Box Pro 5.0: Battery nominal capacity is 5.12 kWh (Includes 2pcs of B-Plus L 2.5)

Battery-Box Pro 7.5: Battery nominal capacity is 7.68 kWh (Includes 3pcs of B-Plus L 2.5)

Battery-Box Pro 10.0: Battery nominal capacity is 10.24 kWh (Includes 4pcs of B-Plus L 2.5)

### 1.5 Identifying the product

The Type Label describes the product identification, which is attached on the product.

The Type Label includes following information:

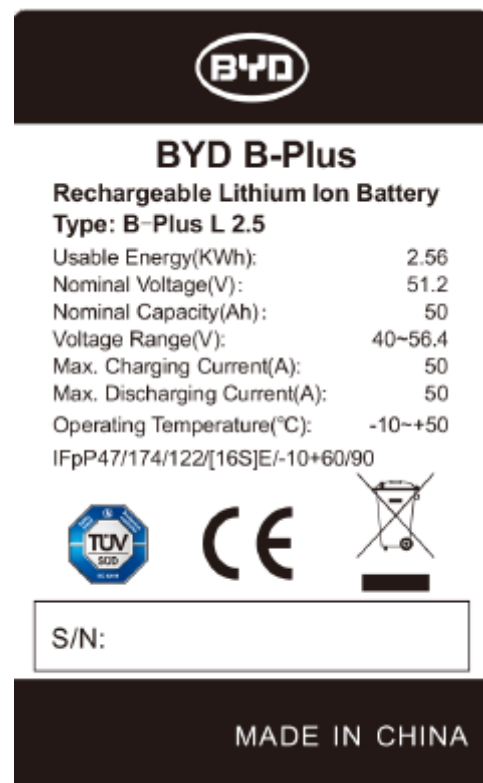
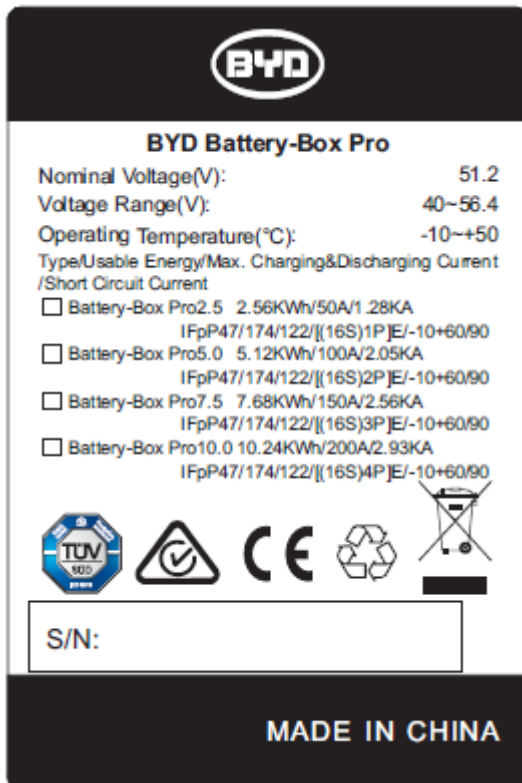

## 2 Safety

This section contains safety information that must be observed at all times when working on or with batteries. To prevent personal injury or property damage and to ensure long-term operation of the batteries, read this section carefully and observe all safety information at all times.



### WARNING

Environmental requirement

- Do not expose the battery to temperature above 50°C.
- Do not install or use the battery near any heat sources.
- Do not install or use the battery in wet locations, such as bathroom.
- Do not expose them to moisture or liquids.

- Do not expose the battery to corrosive gases or liquids.
- Do not expose the battery to direct sunlight for extended periods of time.
- Place battery in secure location away from children and animals.
- Do not allow the battery power terminals to touch conductive objects such as wires.
- Do not dispose of batteries in a fire, which may explode.

#### Operating requirement

- Do not touch the battery pack with wet hands.
- Do not crush, drop or puncture the battery.
- Always dispose of the batteries according to local safety regulations.
- Store and recharge battery in a manner in accordance with this user manual.
- Ensure reliable grounding.
- The charging circuit of inverter shall be DVC A, and the output circuit needs to be isolated from high voltage bus.
- The cabinet and battery modules shall be transported separately to reduce the risk of damage caused by drop, vibration, topple, etc.
- Do not short circuit the terminals, remove all metal objects including watches and rings that could product a short circuit before installation, replacement and maintenance.
- The battery shall be repaired, replaced or maintained by skilled personal recognized. (Skilled personnel recognized is a trained and qualified electrician or installer defined in installation guidance).
- Do not reverse the polarity.
- An external Bi-Polar DC isolator between battery and inverter is required during installation.
- Do not stack up batteries without protective package, when store or handle batteries.
- Do not open, mutilate or disassemble the battery, the released electrolyte, which may be toxic, is harmful to the skin and eyes.
- Disconnect the charging source prior to connecting or disconnecting battery terminals, for instance, disconnect battery from power/load and then power off battery before installation and maintenance.
- Packaged batteries should not be stacked more than specified number stipulated on the package.
- Do not lay tools or metal parts on top of batteries.
- Do not use damaged, failed or deformed batteries, which may reach temperatures that exceed the burn thresholds for touchable surfaces. Continued operation of damaged battery may result in dangerous situation and cause severe injury due to electrical shock.

### 3 Technical Data

Item	Battery-Box Pro 2.5	Battery-Box Pro 5.0	Battery-Box Pro 7.5	Battery-Box Pro 10.0
Battery type	Lithium Iron Phosphate Battery			
Battery module	B-Plus L 2.5			
Usable battery energy(kWh)(100% DOD, 0.5C	2.56	5.12	7.68	10.24
Max output power(kW)	2.56	5.12	7.68	10.24
Charge & discharge at @+25°C)(kWh)	2.56	5.12	7.68	10.24
Short current(kA)	1.28	2.05	2.56	2.93
Nominal voltage(V)	51.2			
Operating voltage range(V)	43.2~56.4			
Ambient temperature range(°C)	-10~+50			
Communication	RS485/CAN			
Cabinet net dimension(W*D*H mm)(Without ground feet)	600* 510* 883			
Net weight(kg)	79	113	146	180
IP level	IP20			
Note: The maximum operating voltage of the rechargeable lithium-ion battery system is less than 60Vd.c				

When Battery-Box works in different temperatures, the current of charge and discharge will be adjusted automatically, battery will permit lower current when operating temperature gets lower. Please refer to below table for the detail parameters setting:

Charging current at different temperature ranges	
Operating temp. (°C)	Max. charging current(A)
-7~2	0.06C*N
2~12	0.17C*N
12~50	0.7C*N

Remark:

1. Effective time is 2mins when changing from one temperature range to another.
2. N=B-Plus L 2.5 battery quantity

Discharging current at different temperature ranges	
Operating temp.(°C)	Max. discharging current(A)
-10~50	0.7~1C*N

Remark:

1. N= B-Plus L 2.5 battery quantity

## 4 Technical Terms

No.	Term	Comment
1	Discharge	Battery output power for load
2	Charge	To put electricity into battery by charger
3	Full charged	Battery had been full charged, SOC is 100%.
4	Idle	Battery is on status of neither charge nor discharge and has not been fully charged.
5	Shutdown mode	Power off
6	SOC	State of Charge
7	SW	Software
8	HW	Hardware
9	Battery voltage	The voltage between B+/B-
10	Pack voltage	The voltage between P+/P-
11	Cell voltage	Single cell voltage
12	Failure	Battery or BMS are broken, and unit needs to be replaced
13	Alarm	Battery will stop charging or discharging immediately
14	Protect	Battery stops charging or discharging (e.g. cell is overvoltage). Operation can resume at a later stage.
15	Over discharged	Battery module or batteries overvoltage, need to be recharged timely

## 5 Product Overview

### 5.1 Brief introduction of Battery-Box system

The Battery-Box energy storage system, combined with high-performance BYD lithium battery, consists of cabinet, battery and BMU. Up to 4 battery modules can be installed in one cabinet for use, and the usable energy can be extended easily from 2.5kWh to 80kWh by parallel connection.

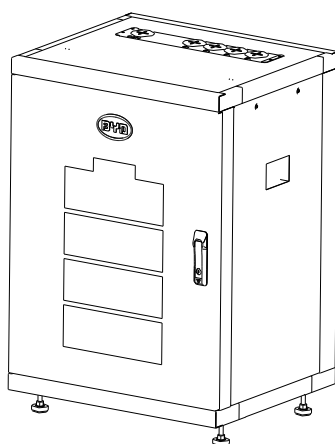

External drawing

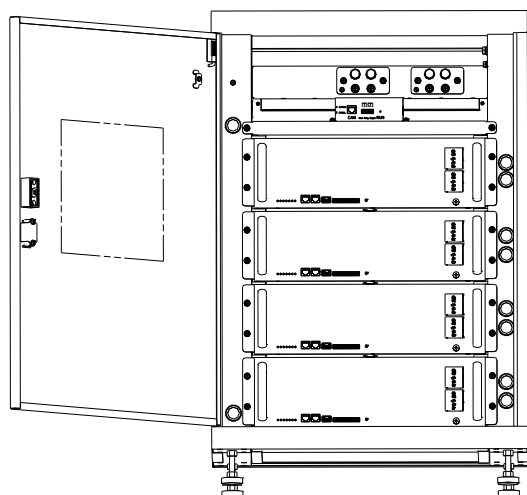

Internal drawing

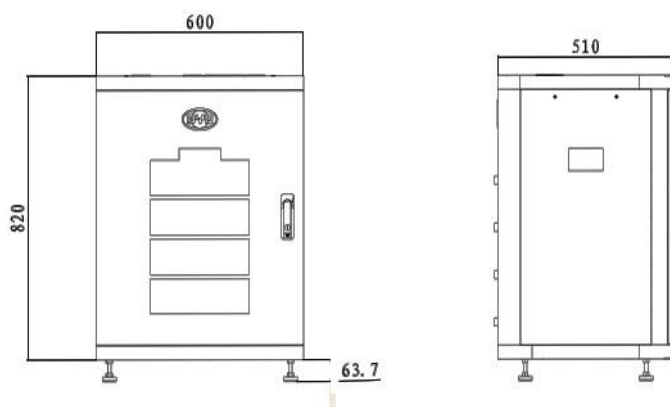

Structure dimension drawing

## 5.2 Configuration table

No.	Component	Name	Description
1	Cabinet	Battery-Box Cabinet	The cabinet is used to accommodate the B-Plus L 2.5 L modules and provide DC output.(Up to 4 B-Plus L 2.5 can be accommodated)
2	Battery	B-Plus L 2.5	Battery module with 51.2V 50Ah, BYD' s P/N is: U3A1-50P-A.
3	BMU	BMU	The battery management unit. It communicates with external equipment.

## 5.3 Introduction of BMU

BMU, the battery management unit installed inside the cabinet, communicates with BMS and external equipment.



Main functions:

- ✓ CAN / RS485 communication with inverter
- ✓ RS485 communicate with battery/BMS
- ✓ Dry contact terminal
- ✓ Other Communication interface for maintenance
- ✓ Charge and discharge management

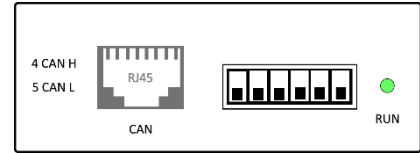

5.4 Introduction of B-Plus L 2.5

B-Plus L 2.5 is the commercial name of BYD’s U3A1-50P-A backup battery with 51.2V & 50Ah, which is designed for energy storage applications. The B-Plus L 2.5 is an integrated battery which consists of enclosure, BMS and cells.

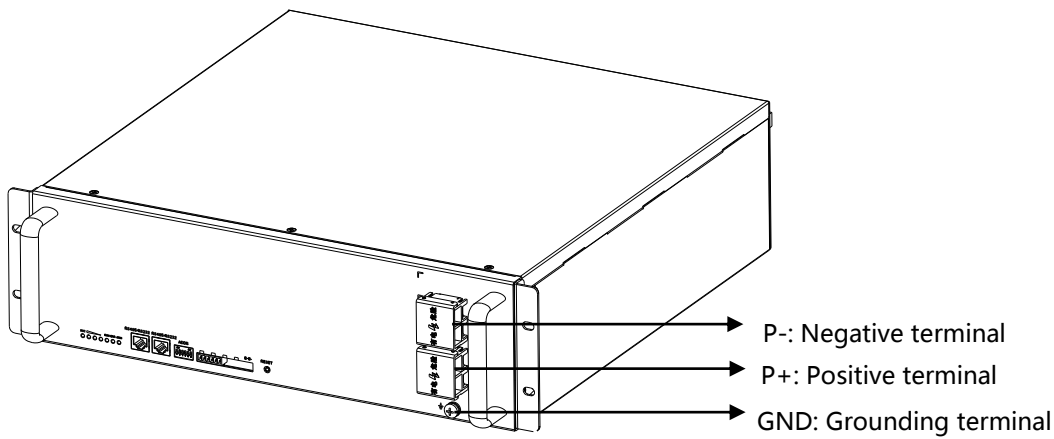

B-Plus L 2.5 overview

Display and communication interface

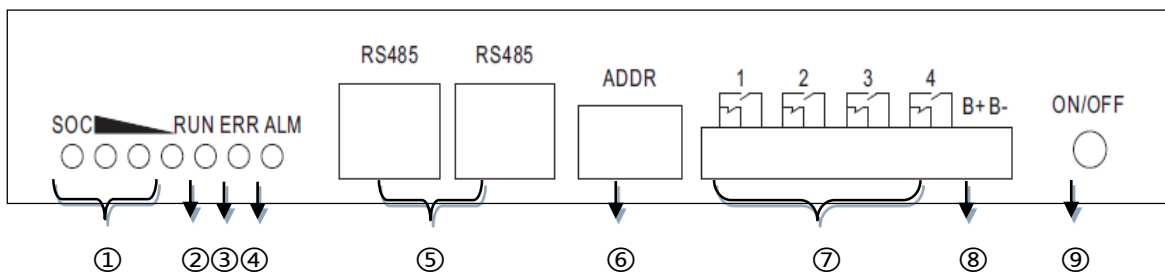

Display and communication interface

No.	Interface	Mark	Function
①	SOC LED	SOC	Indicate current SOC of battery
②	RUN LED	RUN	Indicate that the B-plus L is in running status

③	ERR LED	ERR ADDR	Indicate error status
④	ALM LED	Alarm	Indicate alarm status
⑤	RJ45 terminal	RS485	Communication ports
⑥	Address	ADDR	Address needs to be set, if they are connected in parallel.
⑦	Alarm relay	1.2.3.4	N/A
⑧	Test terminal	B- B+	Measure battery voltage when testing.
⑨	ON/OFF	ON/OFF	Power on/power off manually

## 5.5 Operating environment

Operating environment parameters

No.	Item	Min.	Typical	Max.	Unit	Remark
1	Discharging temperature	-10	25	50	°C	
2	Charging temperature	-10	25	50	°C	
3	Relative humidity	5		95	%	
4	Absolute humidity	0.26		25	g/m3	
5	Elevation	-	2000	-	m	
6	Enclosure		IP20			

# 6 Cleaning and Maintenance

## 6.1 Cleaning



### CAUTION:

Please power off the system before cleaning the Battery-Box system

The Battery-Box system is recommended to be cleaned periodically. If the enclosure is dirty, please use a soft, dry brush or a soot blower to remove the dust. Liquids such as solvents, abrasives or corrosive liquids are not allowed to clean the enclosure.

## 6.2 Maintenance

### 6.2.1 Recharge requirement for batteries in normal storage

Batteries should be stored in position with the temperature range of -10°C ~ +45°C, and maintained regularly according to the following table with 0.5C (25A) current for 1 hour after a long time of storage.

Recharge conditions for batteries in normal storage

Storage environment temperature	Relative humidity of storage environment	Storage time	SOC
Below -10°C	/	Avoid	/
-10~25°C	5%~85%	≤12 months	30%≤SOC≤60%
25~35°C	5%~85%	≤6months	30%≤SOC≤60%
35~45°C	5%~85%	≤3months	30%≤SOC≤60%
Above 45°C	/	Avoid	/

## 6.2.2 Recharge requirement for over discharged batteries

Please recharge the over discharged batteries in time as per the following table, otherwise the over discharged ones will be damaged.

Recharge condition for over discharged batteries

Storage environment temperature	Storage time
-20~25°C	≤15 days
25~45°C	≤7 days

## 7 Compatible Inverter List

To make sure that the system can be operated normally, please use BYD compatible inverters and select battery quantity correctly, according to the BYD Battery-Box Pro 2.5~10.0 Compatible Inverter List.

## 8 Common Issues and Solutions

### 8.1 Alarm indicated by the BMU and solution

BMU LED flash	Possible cause	Solution
Flash 1 time	Inverter and BMU communication failure	Step1. Check whether the CAN communication cable has been connected correctly and tightly ; Step2. If the connection is incorrect, please reconnect the cable correctly; if the connection is correct and reliable, then replace the BMU ;
Flash 2 times	Battery not found	Check the connection between BMU and first battery.
Flash 3 times	One or some batteries are disconnected	1. Check RS485 cable and battery address 2. If the connection and the address are correct, please contact the after service provider
Flash 4 times	Any battery failure	Check battery led status. If the red led is on and buzzer alarms, please contact the after service provider to replace the battery.

### 8.2 Alarm displayed on B-Plus L 2.5 and solution

Alarm indicated by flashing LED

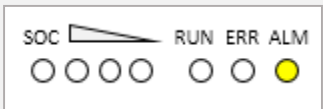
Info B-Plus L displayed	Flashinig	Possible cause	Solution
Only yellow led is ON 	0.5Hz	Battery was powered off abnormally;	Press ON/OFF button for 2-3 seconds to restart the battery, If the battery cannot be recovered, contact the after service provider immediately;

Flow led flashes and alternates with capacity led	10s per cycle	Communication connection timeout	Step1.Check the communication wire/cable Step2.Check battery address
NO.1/3 led and No.2/4 led flashing alternately	/	Update status	If the firmware is not updated, then reset the battery.

Alarm indicated by flashing yellow led

Fault phenomenon	Flashing	Possible causes	Solution
1.Yellow led (Alarm) is always on  2 Press on/off button for 1S and release, then buzzer sounds shortly;  3. The green Led (RUN) is always on, and yellow led (ALM) flashing, which indicates alarm status.	1time	Under voltage (BAT or CELL)	Contact the after service provider
	2times	Over charge	Contact the after service provider
	3times	Low temperature charge over-current	Contact the after service provider
	4times	Charge short circuit	Contact the after service provider
	5times	Discharge short circuit	Contact the after service provider
	6times	Parallel short circuit	Contact the after service provider
	7times	Discharge over-current protection	Contact the after service provider
	8times	High temperature protection	Contact the after service provider
	9times	Low temperature protection	Contact the after service provider
	10times	PACK over voltage protection	Contact the after service provider

Alarm indicated by flashing red led

Fault phenomenon	Flashing	Possible causes	Solution
1.Red led (Err) is always on  2. Press the on/off button press the for1S	1time	Voltage sensor failure	Replace the battery

and released, then buzzer sounds shortly			
3. Green led (RUN) is always on, and red led (ERR) is flashing, which shows the alarm status.	2times	Temperature sensor failure	Replace the battery
	3times	Charging circuit failure	Replace the battery
	4times	Discharge circuit failure	Replace the battery
	5times	Batteries failure	Replace the battery
	6times	Communication failure	Replace the battery

Info displayed on B-Plus L

Fault phenomenon	Beep	Possible cause	Solution
The buzzer sounds at a 15 seconds interval.	4times	Reverse 、 short circuit	1.Power off; 2.Inspect short/reverse connection of cable between P+&P-; 3.If short/reverse connection is confirmed, please reconnect cable correctly; 4.Restart battery;
	3times	Batteries failure	Replace the battery
	2times	Voltage sensor failure、 Temperature sensor failure	Replace the battery
	1time	Charging/Discharge circuit failure	Replace the battery

### 8.3 Common issues displayed on inverter and solution

User also can check the battery' s running, warning and alarm information from App or LED display of inverter.

### 8.4 Emergency

Please cut off the power supply and turn off the battery in emergency.

---

## 9 Warranty

BYD provides warranty when the product is installed and used according to the description of user manual / installation manual / warranty letter.

1. Please contact our local service provider for technical support & after service.
2. Please download the Warranty Letter via following website:

Australia customer: [www.alppower.com.au](http://www.alppower.com.au)

European customer: [www.eft-systems.de](http://www.eft-systems.de)

# Contact Information

China

BYD LITHIUM BATTERY Co., LTD

E-Mail: eubatterygrp@byd.com

Tel: +86 0755 89888888

Fax: 0755-8961 9653

Address: No.1 Baoping Road, Baolong Industrial Town, Longgang Shenzhen, 518116, China

---

## Local Service Provider

Australia

ALPS POWER PTY LTD

14/47-51 Lorraine St Peakhurst NSW 2210

+61 2 8005 6688

Email: [service@alpspower.com.au](mailto:service@alpspower.com.au)

[www.alpspower.com.au](http://www.alpspower.com.au)

Europe

EFT-Systems GmbH

Buchenstr.37 97816 Lohr a. Main

Customer Service Mailbox: [service@eft-systems.de](mailto:service@eft-systems.de)

+49 9352 8523999(DE)

+34 91 0602267 (ES)

+39 02 87368364 (IT)

+44 2037695998 (UK)

[www.eft-systems.de](http://www.eft-systems.de)