



B-Box H

Installation Guidance

27th_Sep.2017

Contents

SAFETY	3
1 PRODUCT OVERVIEW	4
2 BCU INTRODUCTION	6
3 DESCRIPTION OF B-PLUS-H INTERFACE AND TERMINAL	8
4 B-BOX HV INVERTER CONFIGURATION LIST	9
4.1 B-Box HV CONFIGURATION LIST WITH SMA SUNNY BOY STORAGE	9
4.2 B-Box HV CONFIGURATION LIST WITH KOSTAL PIKO	9
5 PREPARATION	9
5.1 INSTALLATION INSTRUCTIONS	9
5.2 PACKING INFORMATION AND SYSTEM STRUCTURE CONFIGURATION LIST	10
5.3 STRUCTURE CONFIGURATION LIST	10
5.4 INSTALLATION TOOLS	11
5.5 PERSONAL PROTECTION EQUIPMENT	11
6 INSTALLATION OF SINGLE SYSTEM	12
7 CONNECTING WITH THE SBS INVERTER	18
8 SYSTEM BOOT	20
8.1 SWITCH ON THE AIR SWITCH OF BATTERY	20
8.2 SOFTWARE UPDATE AND SYSTEM SETTING	20
8.3 SWITCH ON THE INVERTER, SET UP THE INVERTER PARAMETER	20
8.4 SWITCH ON THE AIR SWITCH OF THE BATTERY, AND THE SYSTEM CAN WORK NORMALLY.	21
9 SYSTEM SHUTDOWN PROCEDURE	22

Website of installation video: <http://www.byd.com/energy/b-box-25.htm>

Safety



Warning

When disassembling the system, avoid touching the battery terminal with any metal objects or human body.

All work relating to electrical connections of the system shall be carried out by qualified personnel only.

All operations of B-Box H relating to electrical connection must be done by professionals.

B-Box H provides a safe source of electric energy when operated as designed.

Potentially hazardous circumstances such as excessive heat or electrolyte mist may occur under improper operating conditions, damage, misuse and abuse. The following safety precautions and the warning messages described in this section must be observed and complied. If any of the following precautions are not fully understood, or if you have any questions, contact customer service for guidance.

Installation and maintenance personnel must review and operate according to applicable federal, state and local regulations as well as the industry standards regarding this product.

Installation workers may not wear metal accessories, etc. in order to avoid short circuit and personal injury.



Warning

During loading, unloading and handling of the product, be cautious, and avoid accidents of product damage and personal injury due to the falling of product.

When adding battery, first disconnect the power supply of the battery and other power input.

To avoid danger, DO NOT remove the BCU module when the system is in operation.

1 Product Overview

B-Box H is the abbreviation of high-voltage battery box, with the operating voltage range within 200~500V. It is applied to the household energy storage field and works together with high-voltage inverter to realize energy storage and release. Each set of battery of the system supports the serial connection of 5~9 battery modules, and parallel connection of 2~5 sets of systems

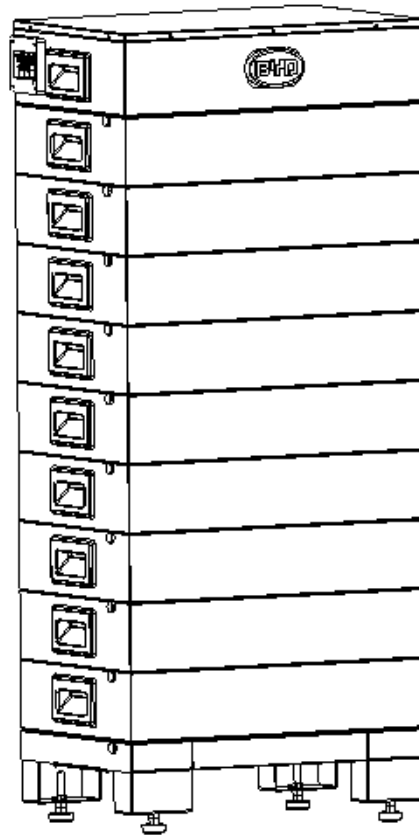

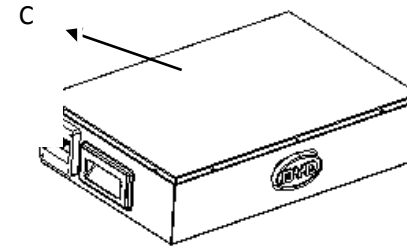
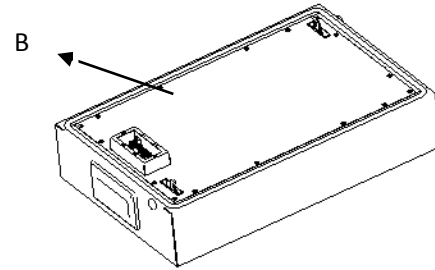
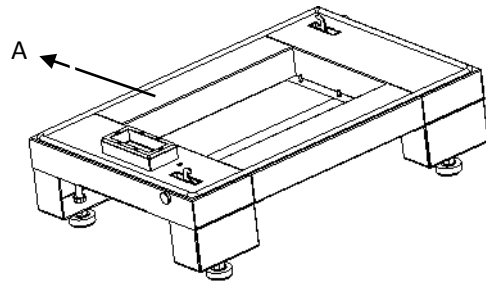

Position	Designation
A	Base
B	B-Plus-H
C	BCU

2 BCU Introduction

The battery management and control part, which contains BCU and charge-discharge relay, and connected to the battery modules underneath and to inverter or BMU above.

Position	Designation	Left side terminals
A	Ethernet	
B	CAN (Inverter)	
C	Grounded	
D	P-	
Position	Designation	Right side terminals
A	Air switch waterproof cover	
B	System Air switch	

Definition of BCU Functional Interfaces

No.	Interface Name	Description
1	P+	The system positive terminal, connected to the positive terminal of battery interface of inverter.
2	P-	The system negative terminal, connected to the negative terminal of battery interface of inverter.
3	GND	Grounding terminal, connected to the ground.
4	Ethernet	Connected to the Ethernet, to complete the functions of communication and remote program update.
5	Inverter communication	Contain RS485, CAN, and enable signals, outputting 13V power.
6	System switch	The main switch of system, which can be operated manually and has short circuit protection function.

3 Description of B-Plus-H Interface and Terminal

The battery module provides energy and sends the information about the cell voltage and cell temperature in the battery module to the upper-layer BCU.

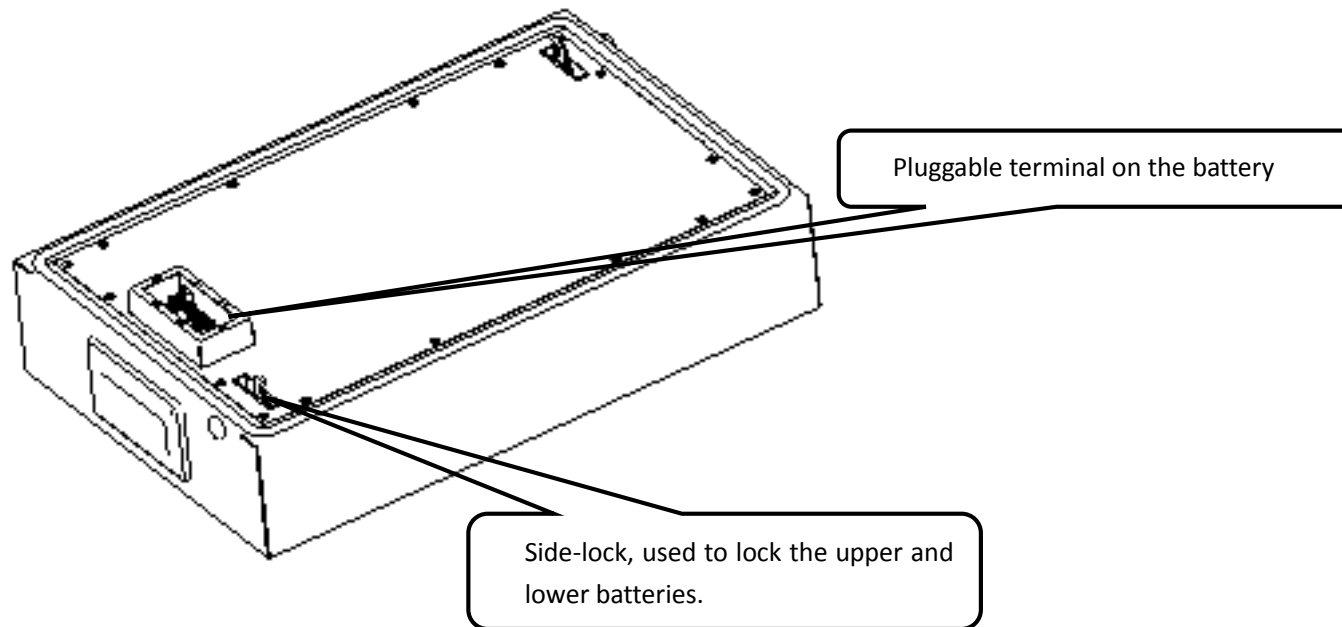

4 B-Box HV Inverter Configuration List

4.1 B-Box HV Configuration List with SMA Sunny Boy Storage

1 Phase on Grid		
Inverter Type	B-Plus-H quantity	BCU quantity
SBS 2.5	5 ~ 9	1

4.2 B-Box HV Configuration List with Kostal Piko

3 Phase on Grid		
Inverter Type	B-Plus-H quantity	BCU quantity
PIKO 6.0 BA	5 ~ 9	1

5 Preparation

5.1 Installation Instructions

- Before installation, ensure that BCU manual switch is switch off.
- The battery shall be installed in a place away from heating source and avoid sparks. The safety distance is greater than 0.5m.
- The connecting cables for installing batteries shall be as short as possible, to prevent excessive voltage drop.
- Batteries of different capacity, different P/N or from different manufacturers cannot be connected.

- e) After installation, ensure the positive and negative terminals of BCU and inverter are connected correctly.
- f) The installation place shall be on a flat ground, without accumulated water.

5.2 Packing Information and System Structure Configuration List

The battery, BCU+ base are packed in separate carton. Before installation, the installation personnel shall read the system configuration list.

No.	Item Description	Qty	Purpose	Picture
1	Installation Manual	1	Provide guidance for field installation.	\
2	User Manual	1	System information and using method and warranty items.	\

5.3 Structure Configuration List

Type	H6.4	H7.7	H9.0	H10.2	H11.5
BCU + Base	1	1	1	1	1
B-Plus H	5	6	7	8	9
User manual	1	1	1	1	1
Installation guide	1	1	1	1	1

5.4 Installation Tools



Screwdriver suit



Crimping pliers



Crimping pliers



Diagonal cutters



Adjustable wrench



Inner hexagon spanner

5.5 Personal Protection Equipment



Insulated gloves



Safety shoes

6 Installation of Single System

Step 1: open the battery package;

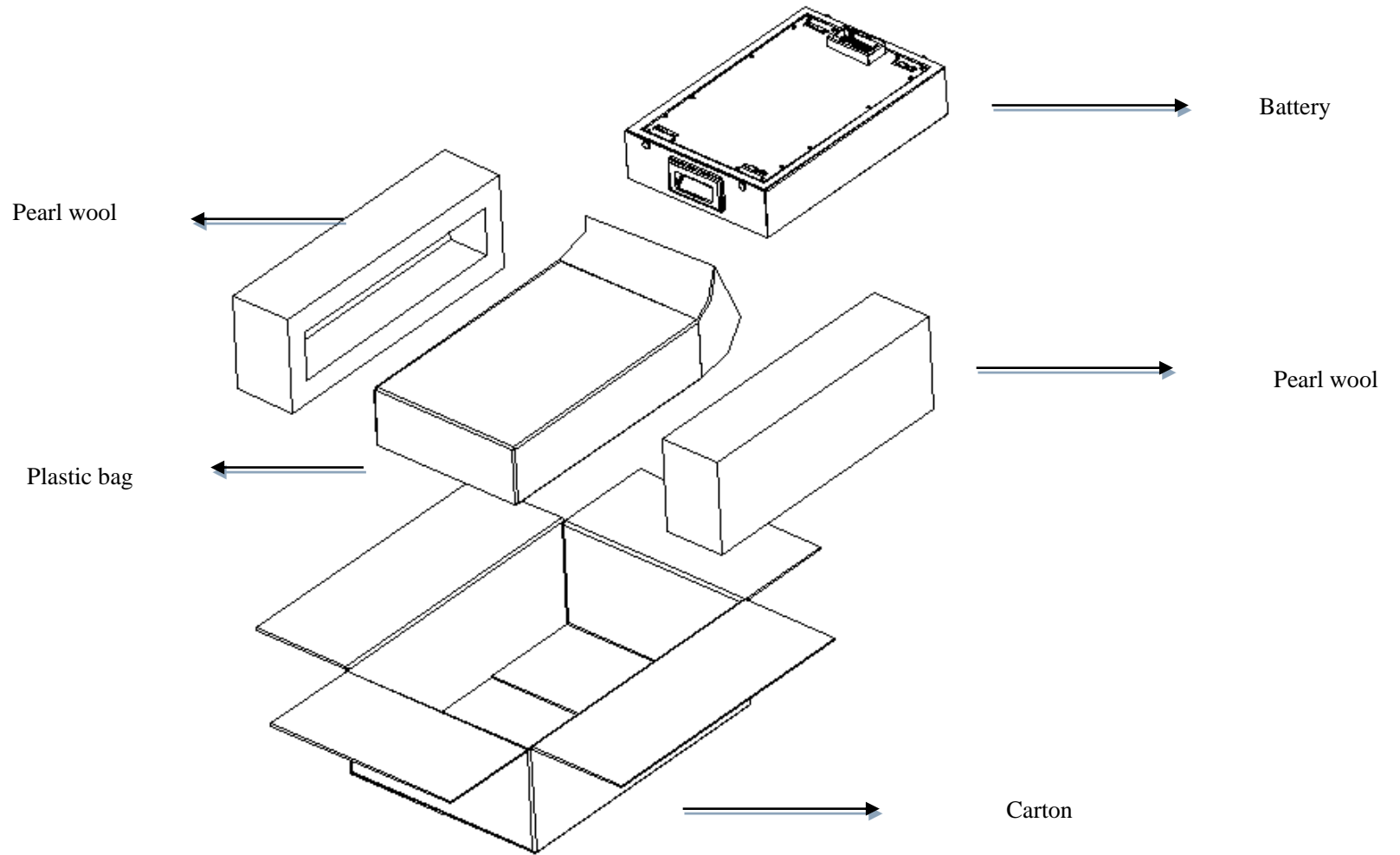

Step 2: Take out the BCU & Base, BCU & Base are locked and packed in the same box (the method is the same as the first step); unlock the lock with inner hexagon spanner, separate the BCU and the base.

Tool: Inner hexagon spanner

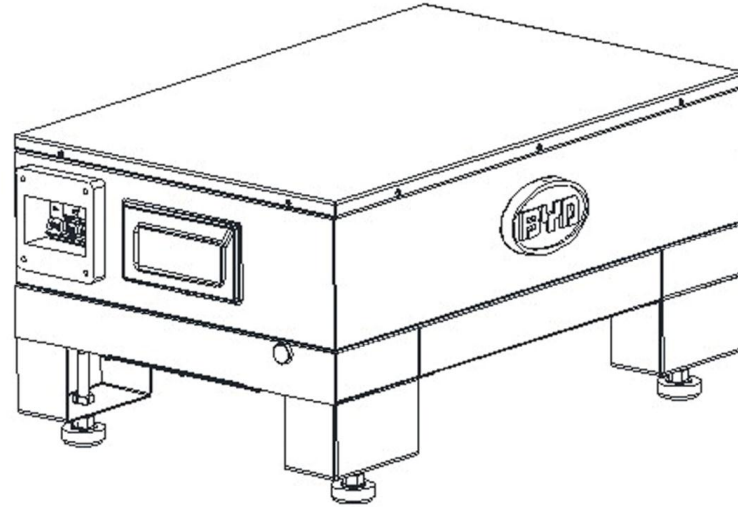

BCU & Base

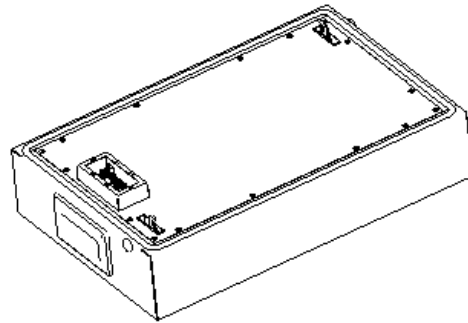

B-Plus-H

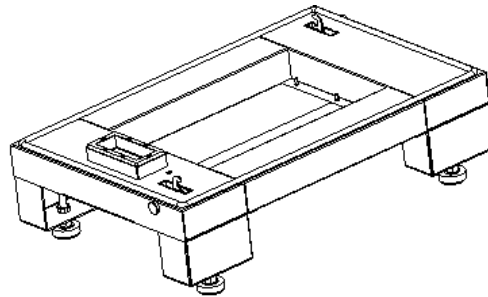

Base

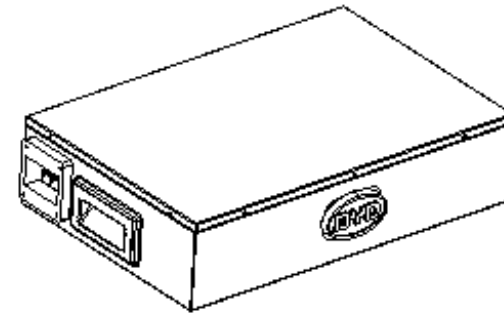

BCU

Step 3: adjust the support of the base; drill 4 holes on the wall with M6 expansion bolt (the distance between ground and the bottom holes depends on different module numbers, please refer to picture below; the distance between the bottom two holes and upper two holes is 80mm; the distance between the right two holes and left two holes is 200mm; the distance between the right edge to the right two holes is 190mm; the distance between the left edge to the left two holes is 190mm.); mount the fixing plate to the wall, and install the fixing arch onto the BCU module.

Tools: Cross screwdriver, impact drill, adjustable wrench

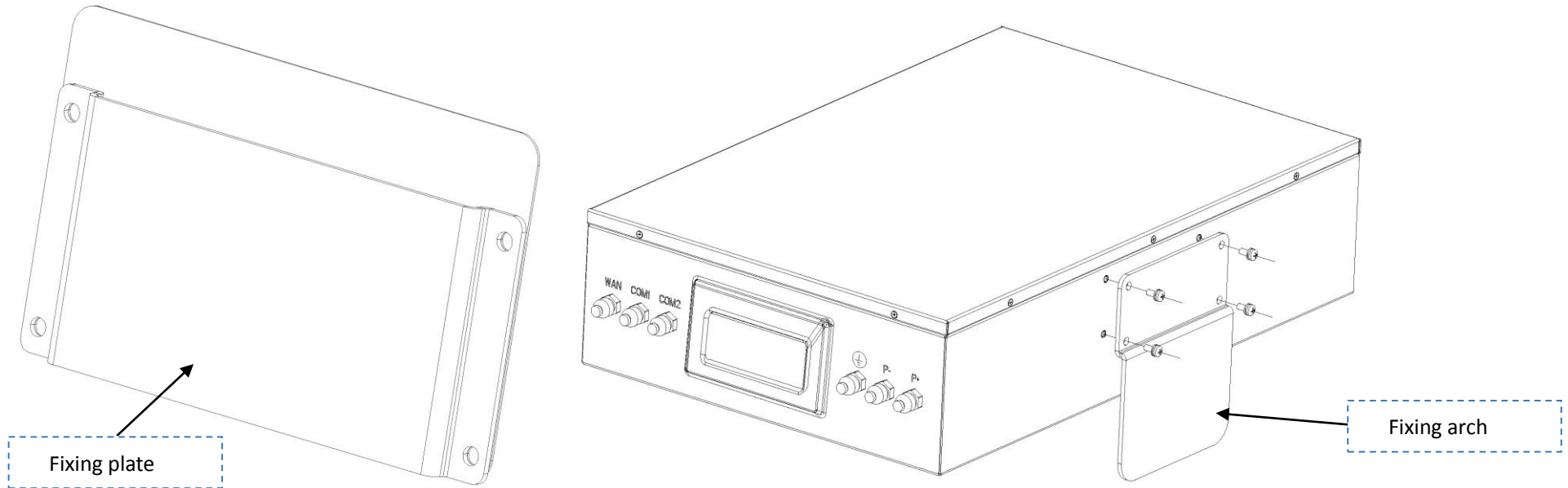

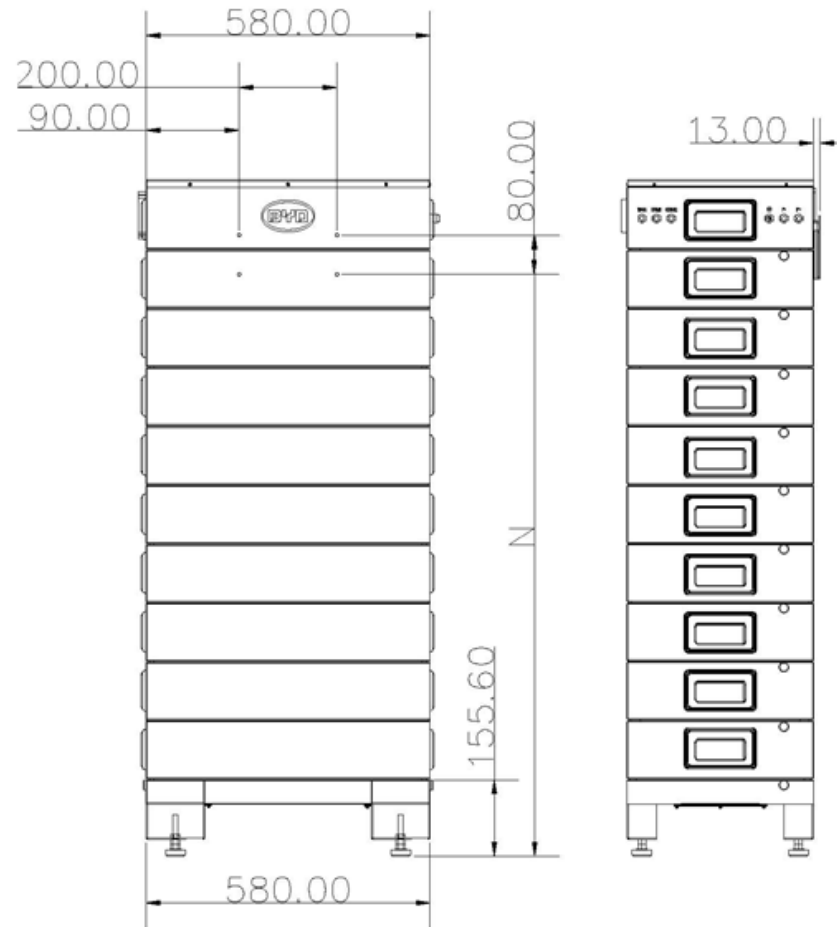

Serial number	5	6	7	8	9
Bottom hole height(mm) N	786.1	906.1	1026.1	1146.1	1266.1

Remark: The bracket are needed to replaced by another proposal due to hard to install, so it should be permitted to do not install the bracket untill we provide the new bracket.

Step 4: Install the batteries (5pcs~8pcs), and lock the batteries with the base, ; then install BCU, and lock the batteries with BCU; the installation is completed.

Tool: Inner hexagon spanner

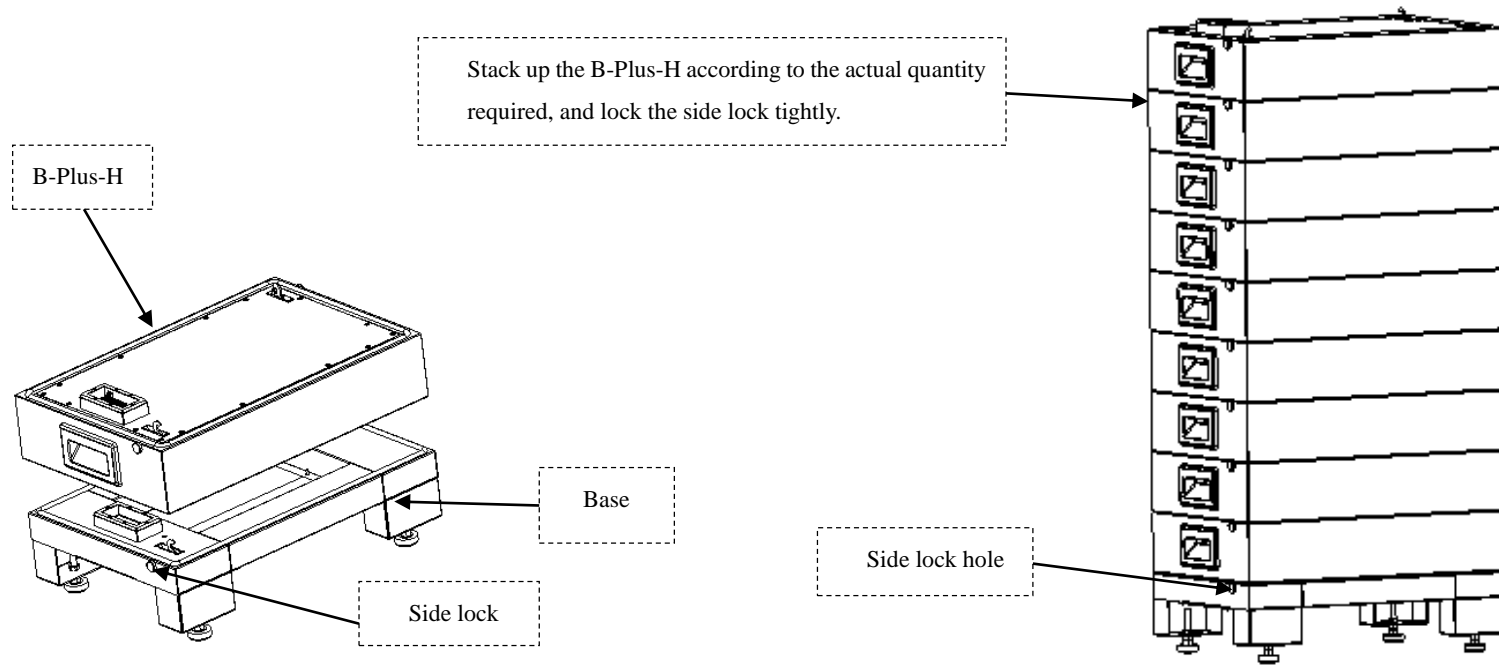

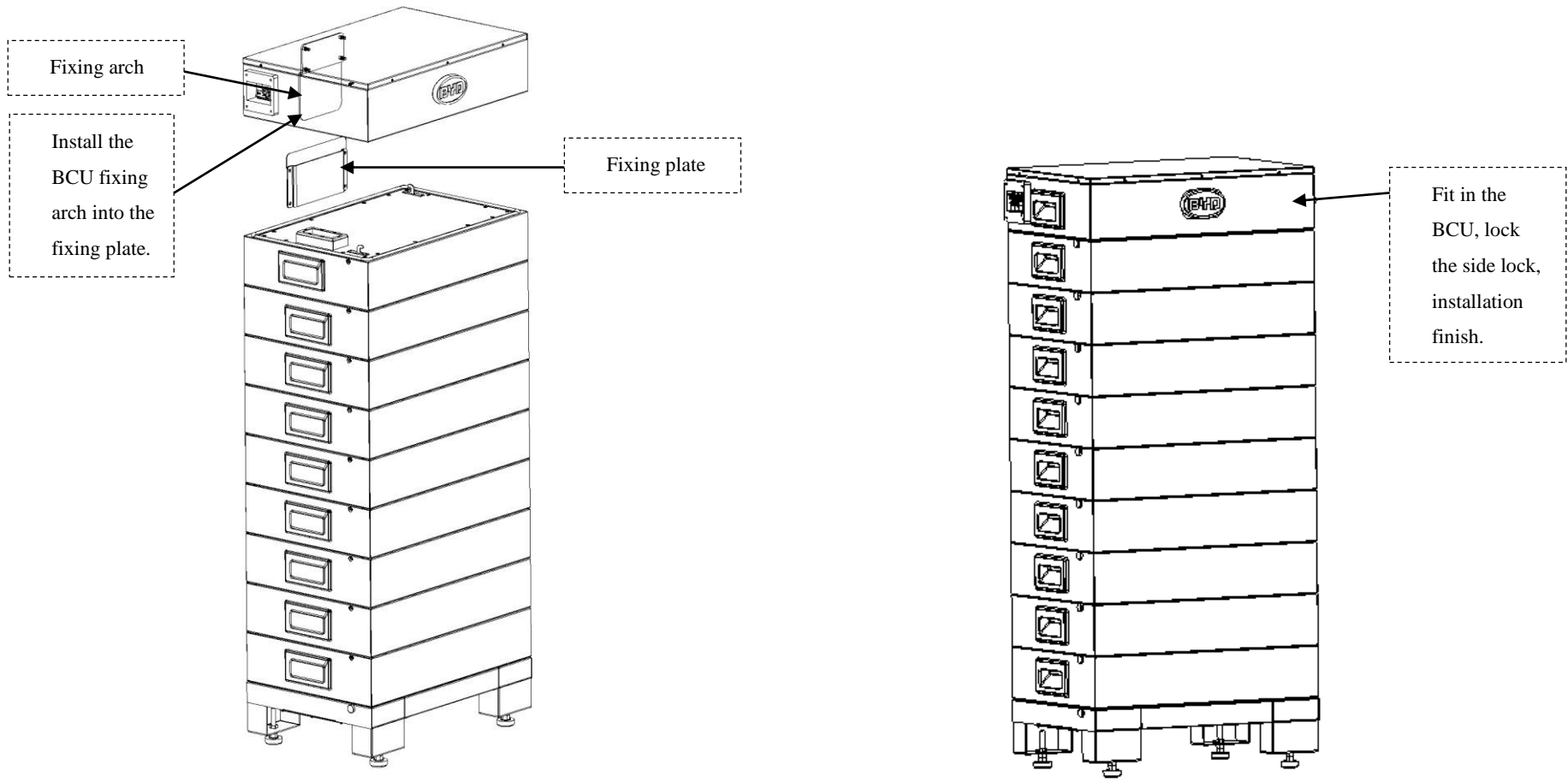

7 Connecting with the SBS Inverter

Tools: Cross screwdriver, with torque force: 25 ± 2.5 Nm.

1. Open the top cover of the BCU.
2. Connect the power cable: get the positive and negative cables through the PG head, connect them into BCU case, and then install them onto the positive and negative terminals respectively.
3. Connect the communication cable and Ethernet cable: connect the communication cable. The definition of communication cable is as follows:

Pin	Definition	Description
2	EN 11V+	Positive terminal for inverter enable signal interface
4	EN 11V-	Negative terminal for inverter enable signal interface
6	CANH	
8	CANL	
9	Shield	Signal line shielding layer, not necessary.

Cable recommendation:

Cable definition	Cable diameter (mm)	Sectional area (mm ²)	Recommended cable type
P+ connection cable	Φ4~Φ6.8	6~10	UL1015 10AWG-8AWG
P- connection cable	Φ4~Φ6.8	6~10	UL1015 10AWG-8AWG
Grounding cable	Φ4~Φ6.8	6~10	UL1015 10AWG-8AWG
Communication cable	Φ4~Φ6.8	/	cat5e or above
Ethernet cable	Φ4~Φ6.8	/	cat5e or above

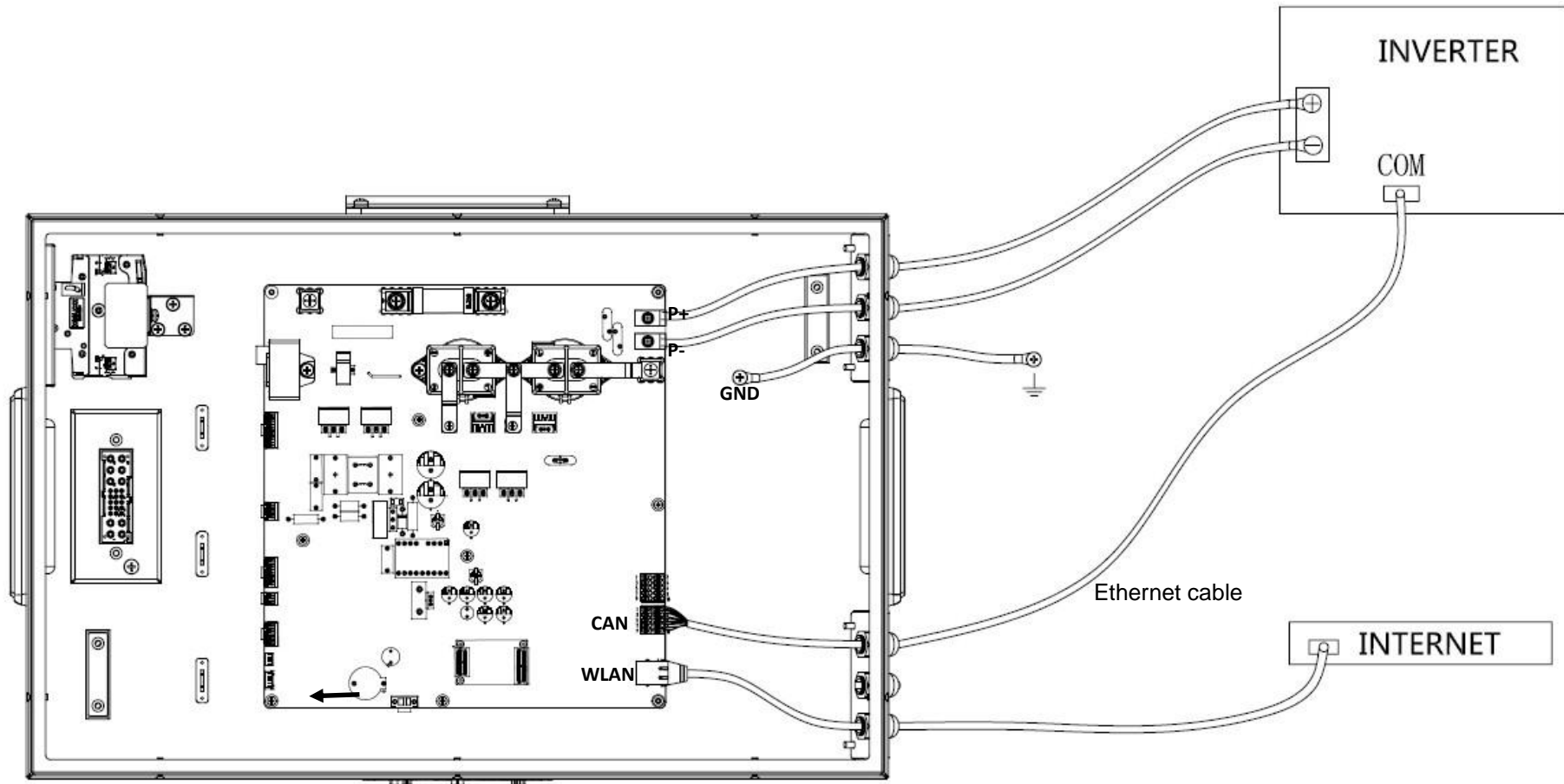

Caution :

- 1 Before connect operation, please make sure of the air switch is on "OFF".
- 2 Please do not reverse connect P+ and P-.
- 3 Please make sure of reliable grounding.

8 System Boot

Note: Before activating the system, please check the following items:

1. Confirm the inverter is not connected reversely;
2. Ensure reliable connection of communication cable between battery and inverter.
3. If the matched inverter is CAN communication, Jumper Cap on JP1 position; If the matched inverter is 485 communication, is the Jumper Cap in JP2 position.
4. Before not configured batteries and inverters, banned batteries and inverter to electricity at the same time.

8.1 Switch on the Air Switch of Battery

Caution: Please do not start inverter.

8.2 Software update and system setting

Please download the software and connect system with PC by WIFI, operate following the document of "B-Box H Update and initial setting".

Caution: Please update first.

8.3 Switch on the Inverter, set up the inverter parameter.

Please input the blocks after 

✓

➤ Battery switch				
▼ Battery charge				
Set battery charge	➔	0	System nominal capacity	kWh (0 kWh ... 4,000,000 kWh)
▼ Battery discharge				
Set battery discharge	➔	0	System nominal capacity	kWh (0 kWh ... 4,000,000 kWh)
▼ Areas of application				
Lower lmt deep disch. protect area prior shutdown	➔	2	%	(0 % ... 5 %)
Minimum width of deep discharge protection area	➔	3	%	(1 % ... 5 %)
Area width for conserving battery state of charge	➔	5	%	(1 % ... 10 %) ⚠
Minimum width of own consumption area		75	%	(0 % ... 100 %)
Most profitable month		June profitable ▼		
Season operation active		Yes ▼		

8.4 Switch on the air switch of the battery, and the system can work normally.

9 System Shutdown procedure

Note: Please power off the inverter before shutting down the system.

After the system is shut down, check the following items:

The inverter is powered off.

The battery system is switch off.